

Curb Stop:

It is important that all WWWU members be aware of the responsibilities related to the curb stop.

General Description:

Each Wintergreen lot has a curb stop. Your curb stop is the main water shut off valve located near your property boundary adjacent to the easement. The illustration below shows a typical curb stop valve. When OPEN, this valve permits water to flow from the treatment plant through the Wintergreen distribution system into your home plumbing system. This valve is the only mechanism to shut off water to the property locally.

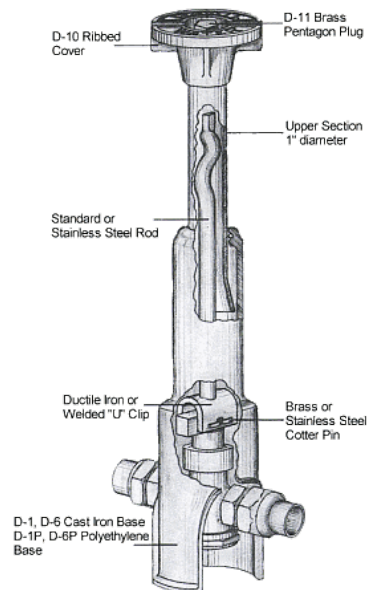

Responsibilities:

Should any water or plumbing malfunctions occur within the property boundary (on your lot or inside the house) that require the main water valve to be shut off, it is critical that the curb stop be accessible and functional. Responsibilities are shared as follows:

Member Responsibility = Property owners must be aware of the location and external condition of their curb stop. In addition, each member should ensure the curb stop remains visible and accessible throughout all seasons.

WWWU Responsibility = The Utility will be responsible for the operational functionality of the curb stop.